

6*918 - Drehriegel, Zinkdruckguss, Kunststoff

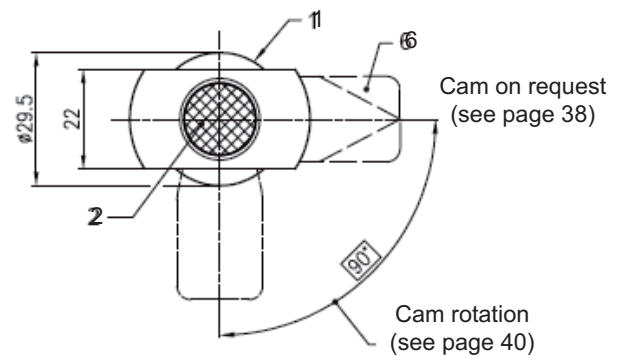
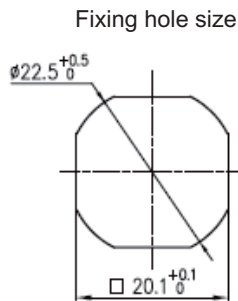
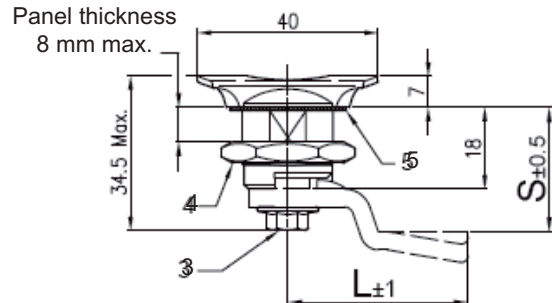
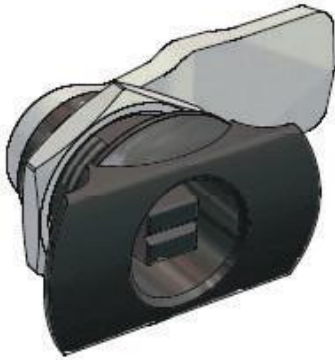

Triangle 6,5 mm

Triangle 8 mm

Slotted recess

Inside hex. 6 mm

Railways square

P3 pin

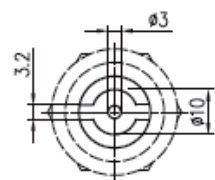
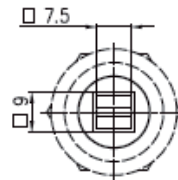
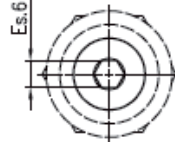
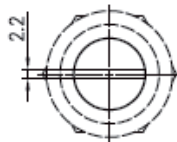

Code: A

Code: B

Code: D

Code: G

Code: M

Code: P

Insert * head style "code" and \varnothing material "code" into lock part number

Lock Part Number
6*918 \varnothing NBW

Ref	Part description	PLASTIC/ZINC ALLOY (NB) Material - Finishing	PLASTIC (PN) Material - Finishing
1	Housing	PA6.6 + 20%GF Black	PA6.6 + 20%GF Black
2	Cylinder	Zinc alloy - Bright chrome	PA6.6 + 20%GF Black
3	Screw M6X10	Steel - white zinc Cr6 free	Steel - white zinc Cr6 free
4	Nut M22X1,5	Steel - white zinc Cr6 free	Steel - white zinc Cr6 free
5	Gasket	NBR	NBR
6	Cam	Steel - white zinc Cr6 free	Steel - white zinc Cr6 free